

TC-01TK VALVE

1PC REDUCED PORT 1000 WOG BALL VALVE, THREADED



DESIGN FEATURES:

- Steam rating: 125 psi WSP
- Blow-out-proof stem design
- Padlocking device
- Body: ASTM A351 Gr.CF8M
- Stem: SS316
- Seat: PTFE
- End Connections: Threaded End
- Working Pressure: 1000 psi
- Temperature Range: -50° to 400° F
- TEST STANDARD: API 598
- Vacuum Service to 29" Hg
- Threaded Type:

ANSI B1.20.1 (NPT)

DIN 259/DIN 2999

ISO 228

BSP

PT

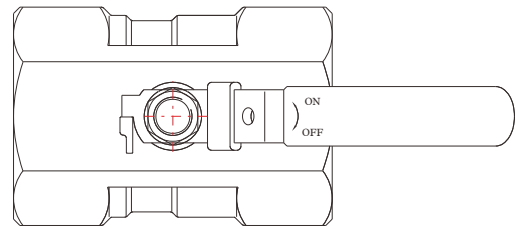

MATERIALS LIST

NO.	PART NAME	MATERIAL	QTY
1	BODY	ASTM A351 Gr.CF8M	1
2	CAP	ASTM A351 Gr.CF8M	1
3	BALL	ASTM A351 Gr.CF8M	1
4	STEM	ASTM A276 Gr.316	1
5	SEAT	PTFE	2
6	THRUST WASHER	PTFE	1
7	PACKING	PTFE	1
8	WASHER	SS304	2
9	SPRING WASHER	SS304	1
10	HANDLE NUT	SS304	1
11	HANDLE	SS304	1
12	HANDLE SLEEVE	VINYL GRIP	1
13	LOCKING PLATE	SS304	1

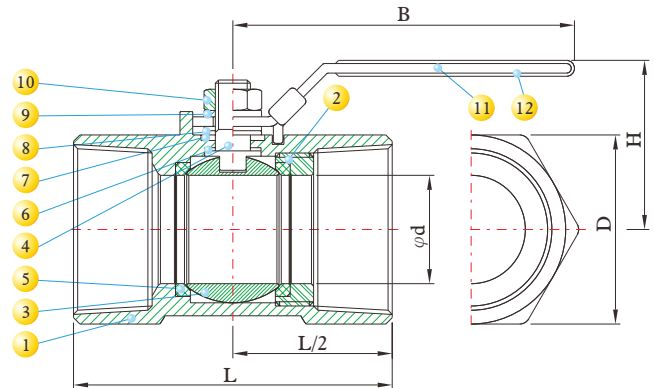

PRESSURE TEMPERATURE RATINGS

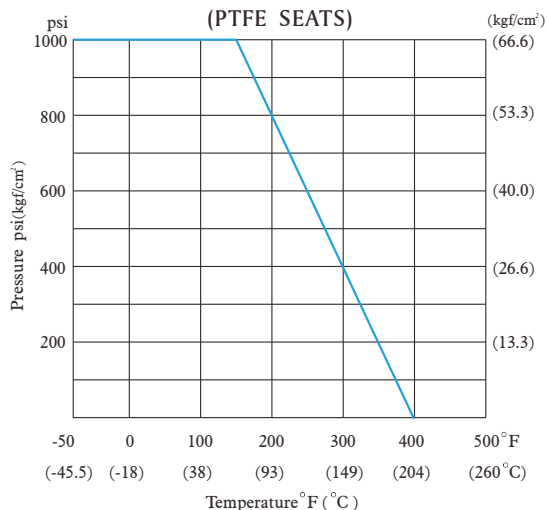

DIMENSIONS

SIZE		d		B		D		L		H		Cv Factor	Weight	
inch	mm	inch	mm	inch	mm	inch	mm	inch	mm	inch	mm		Kg	Lb
1/4"	8	0.20	5.0	2.36	60	0.67	17.0	1.54	39.0	1.22	31	1	0.08	0.18
3/8"	10	0.28	7.0	2.76	70	0.83	21.0	1.73	44.0	1.38	35	2	0.11	0.24
1/2"	15	0.36	9.2	3.39	86	0.98	25.0	2.22	56.0	1.69	43	4	0.17	0.38
3/4"	20	0.49	12.5	3.39	86	1.26	32.0	2.32	59.0	1.81	46	7	0.25	0.55
1"	25	0.63	16.0	4.09	104	1.50	38.0	2.80	71.0	1.97	50	10	0.45	0.99
1 1/4"	32	0.79	20.0	4.09	104	1.93	49.0	3.11	79.0	2.13	54	17	0.74	1.63
1 1/2"	40	0.96	24.5	4.96	126	2.09	53.0	3.27	83.0	2.56	65	26	0.83	1.83
2"	50	1.26	32.0	4.96	126	2.56	65.0	3.94	100.0	2.83	72	45	1.25	2.75

