

TC-02T VALVE

2PC FULL PORT 1000 WOG BALL VALVE, THREADED



DESIGN FEATURES:

- Steam rating: 150 psi WSP
- Blow-out-proof stem design
- Body: ASTM A351 Gr.CF8M
- Ball: SS316
- Stem: SS316
- Seat: Reinforced Teflon
- End Connections: Threaded End
- Working Pressure: 1000 psi
- Temperature Range: -50° to 450° F
- Options: Padlocking device
Tapping for Actuator
- TEST STANDARD: API 598
- Vacuum Service to 29" Hg

MATERIALS LIST

NO.	PART NAME	MATERIAL	Q'TY
1	BODY	ASTM A351 Gr.CF8M	1
2	CAP	ASTM A351 Gr.CF8M	1
3	BALL	ASTM A351 Gr.CF8M	1
4	STEM	ASTM A276 Gr.316	1
5	SEAT	PTFE+15% G/F	2
6	GASKET	PTFE	1
7	THRUST WASHER	PTFE	1
8	PACKING	PTFE	1
9	GLAND	SS304	1
10	HANDLE	SS304	1
11	SPRING WASHER	SS304	1
12	HANDLE NUT	SS304	1
13	HANDLE SLEEVE	VINYL GRIP	1
14	LOCKING PLATE	SS304	1

Threaded Type:
ANSI B1.20.1 (NPT)
DIN 259/DIN 2999
ISO 228
BSP
PT

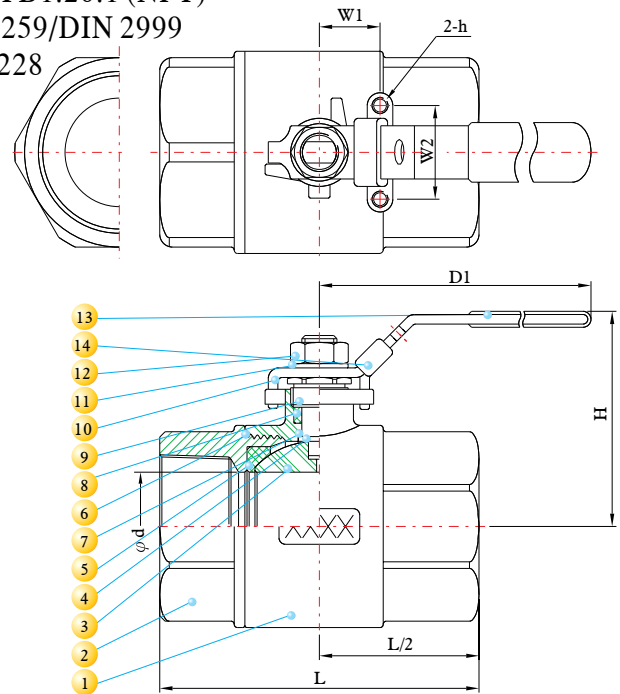

PRESSURE TEMPERATURE RATINGS

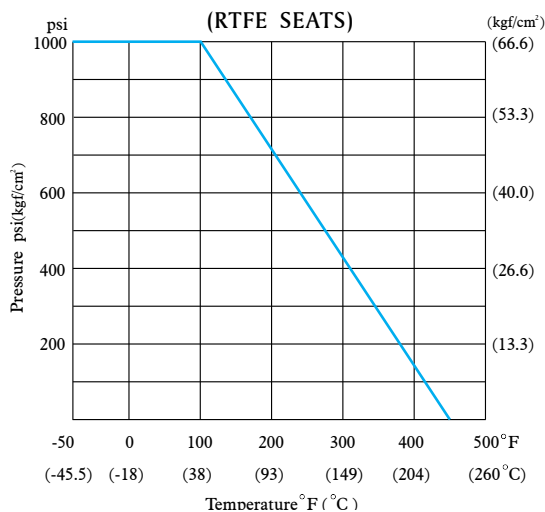

DIMENSIONS

SIZE	d		L		H		D1		W1		W2		h (Option)	Cv Factor	Weight		
	inch	mm	inch	mm	inch	mm	inch	mm	inch	mm	inch	mm			Kg	Lb	
1/4"	8	0.43	11.0	2.34	59.5	2.11	53.5	4.06	103	0.50	12.7	1.12	28.5	M5*p0.8	16	0.35	0.77
3/8"	10	0.49	12.5	2.34	59.5	2.22	56.4	4.06	103	0.50	12.7	1.12	28.5	M5*p0.8	16	0.34	0.75
1/2"	15	0.59	15.0	2.50	63.5	2.17	55.0	4.06	103	0.50	12.7	1.12	28.5	M5*p0.8	26	0.36	0.79
3/4"	20	0.79	20.0	3.02	76.7	2.60	66.0	5.00	127	0.88	22.4	1.38	35.0	M6*p1.0	55	0.65	1.43
1"	25	0.98	25.0	3.56	90.5	2.80	71.0	5.00	127	0.88	22.4	1.38	35.0	M6*p1.0	110	0.93	2.05