

150LB MSS-SP114 CAST FITTINGS INDEX

P9B - 90° ELBOWS BANDED EQUAL	1
PTB - TEES BANDED EQUAL	2
P4B - 45° ELBOWS BANDED EQUAL	3
PSL - STREET ELBOWS 90 ° BANDED	4
P+B - CROSSES BANDED EQUAL	5
PFF - UNIONS F/F	6
PRC - ROUND CAPS	7
PSP - SQUARE HEAD PLUGS	8
PHP - HEX HEAD PLUGS	9
PHT - HEX NUTS	10
PHB - HEX BUSHINGS	11
PHB - HEX BUSHINGS	12
PFC - COUPLINGS / SOCKETS	13
PHC - HALF COUPLINGS	14
PRS - REDUCING COUPLINGS	15
PRS - REDUCING COUPLINGS	16
STANDARD PACKING QUALITY FOR EACH CARTON	17
WEIGHT LIST	18

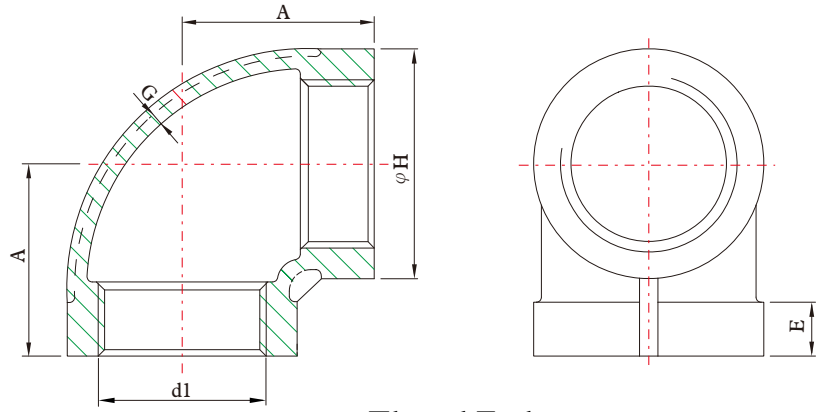



Thread End

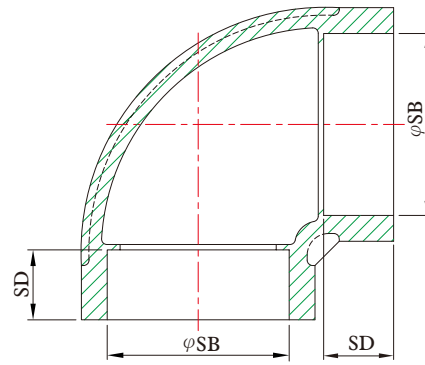

Socket-Weld End

DESIGN FEATURES:

- THREAD: NPT
- CF8 (304) & CF8M (316)
- MEET MSS-SP114

DIMENSIONS

unit : inch

SIZE	A	E	G	H	SB	SD
1/8"	0.81	0.20	0.09	0.75	0.43	0.39
1/4"	0.81	0.20	0.09	0.84	0.56	0.39
3/8"	0.93	0.21	0.10	1.02	0.69	0.39
1/2"	1.12	0.25	0.10	1.21	0.85	0.39
3/4"	1.31	0.27	0.12	1.46	1.07	0.51
1"	1.50	0.30	0.13	1.77	1.33	0.51
1-1/4"	1.75	0.34	0.14	2.15	1.68	0.51
1-1/2"	1.93	0.37	0.15	2.43	1.92	0.51
2"	2.25	0.42	0.17	2.96	2.41	0.63
2-1/2"	2.68	0.48	0.21	3.31	2.91	0.63
3"	3.06	0.55	0.23	4.00	3.54	0.63
4"	3.81	0.66	0.26	5.06	4.55	0.75

TEES BANDED EQUAL

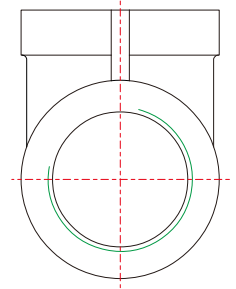
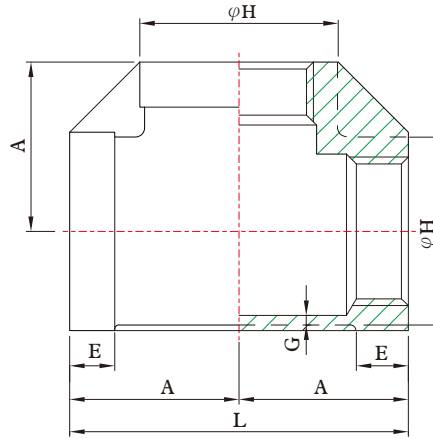

Thread End

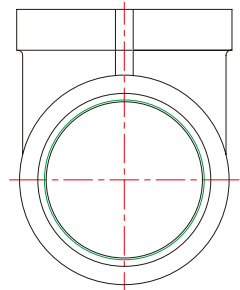
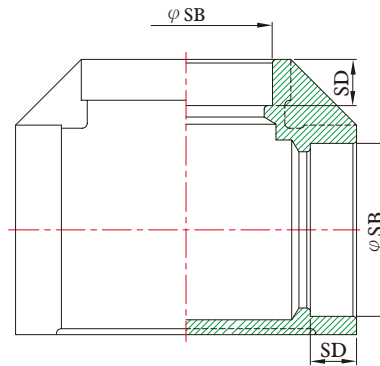

Socket-Weld End

DESIGN FEATURES:

- THREAD: NPT
- CF8 (304) & CF8M (316)
- MEET MSS-SP114

DIMENSIONS

UNIT : inch

SIZE	A	E	G	H	L	SB	SD
1/8"	0.81	0.20	0.09	0.75	1.62	0.43	0.39
1/4"	0.81	0.20	0.09	0.84	1.62	0.56	0.39
3/8"	0.93	0.21	0.10	1.01	1.86	0.69	0.39
1/2"	1.12	0.25	0.10	1.20	2.24	0.85	0.39
3/4"	1.31	0.27	0.12	1.46	2.62	1.07	0.51
1"	1.50	0.30	0.13	1.77	3.00	1.33	0.51
1-1/4"	1.75	0.34	0.14	2.15	3.50	1.68	0.51
1-1/2"	1.93	0.37	0.15	2.43	3.86	1.92	0.51
2"	2.25	0.42	0.17	2.96	4.50	2.41	0.63
2-1/2"	2.68	0.48	0.21	3.31	5.36	2.91	0.63
3"	3.06	0.55	0.23	4.00	6.12	3.54	0.63
4"	3.81	0.66	0.26	5.06	7.62	4.55	0.75

45° ELBOWS BANDED EQUAL

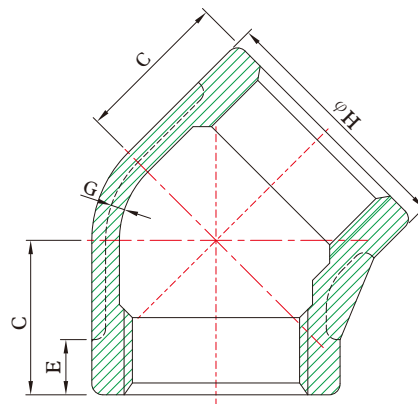

Thread End

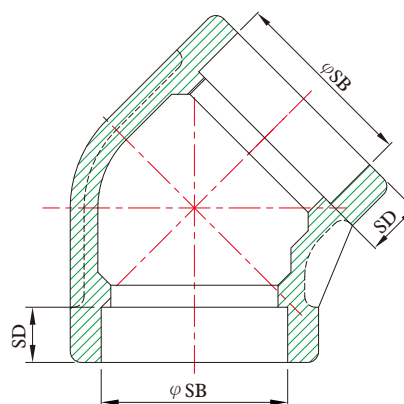

Socket-Weld End

DESIGN FEATURES:

- THREAD: NPT
- CF8 (304) & CF8M (316)
- MEET MSS-SP114

DIMENSIONS

unit : inch

SIZE	C	E	G	H	SB	SD
1/8"	0.69	0.20	0.09	0.75	0.43	0.39
1/4"	0.69	0.20	0.09	0.84	0.56	0.39
3/8"	0.81	0.21	0.10	1.01	0.69	0.39
1/2"	0.87	0.25	0.10	1.20	0.85	0.39
3/4"	1.00	0.27	0.12	1.46	1.07	0.51
1"	1.12	0.30	0.13	1.77	1.33	0.51
1-1/4"	1.31	0.34	0.14	2.15	1.68	0.51
1-1/2"	1.43	0.37	0.15	2.43	1.92	0.51
2"	1.68	0.42	0.17	2.96	2.41	0.63
2-1/2"	1.93	0.48	0.21	3.31	2.91	0.63
3"	2.18	0.55	0.23	4.00	3.54	0.63
4"	2.62	0.66	0.26	5.06	4.55	0.75

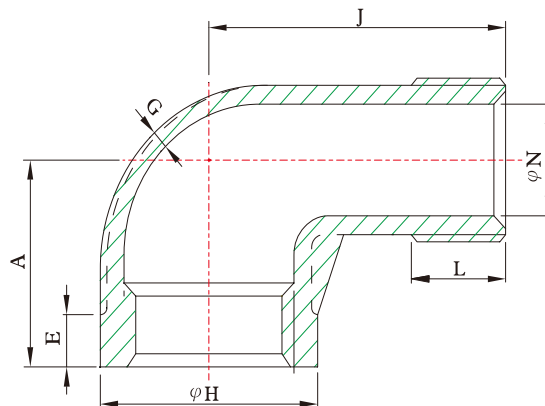

DESIGN FEATURES:

- 🔴 THREAD: NPT
- 🔴 CF8 (304) & CF8M (316)
- 🔴 MEET MSS-SP114

DIMENSIONS

unit : inch

SIZE	A	E	G	H	J	N	L
1/8"	0.81	0.20	0.09	0.75	1.06	0.19	0.26
1/4"	0.81	0.20	0.09	0.84	1.18	0.24	0.40
3/8"	0.93	0.21	0.10	1.01	1.43	0.36	0.41
1/2"	1.12	0.25	0.10	1.20	1.62	0.51	0.53
3/4"	1.31	0.27	0.12	1.46	1.87	0.69	0.55
1"	1.50	0.30	0.13	1.77	2.12	0.91	0.68
1-1/4"	1.75	0.34	0.14	2.15	2.50	1.18	0.71
1-1/2"	1.93	0.37	0.15	2.43	2.75	1.38	0.72
2"	2.25	0.42	0.17	2.96	3.25	1.89	0.76
2-1/2"	2.68	0.48	0.21	3.31	3.87	2.19	1.14
3"	3.06	0.55	0.23	4.00	4.50	2.78	1.20
4"	3.81	0.66	0.26	5.06	5.68	3.68	1.30

CROSSES BANDED EQUAL

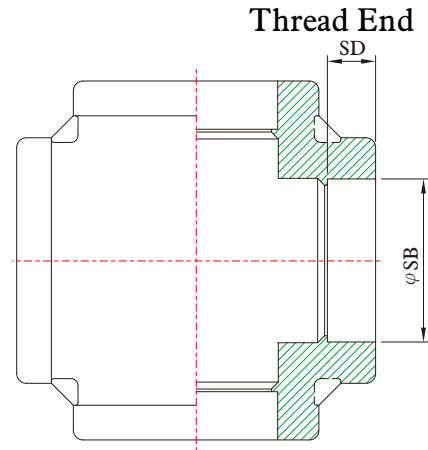
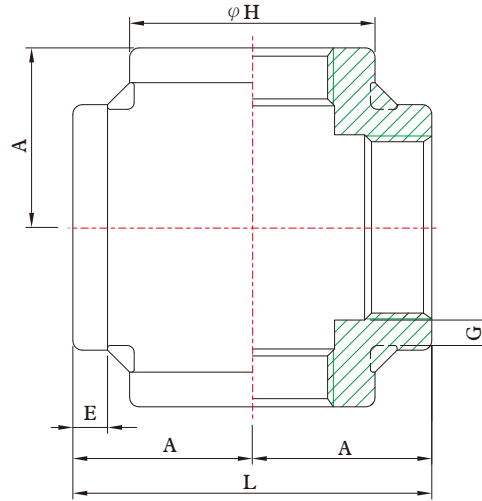

DESIGN FEATURES:

- ☛ THREAD: NPT
- ☛ CF8 (304) & CF8M (316)
- ☛ MEET MSS-SP114

DIMENSIONS

UNIT : inch

SIZE	A	E	G	H	L	SB	SD
1/8"	0.81	0.20	0.09	0.75	1.62	0.43	0.39
1/4"	0.81	0.20	0.09	0.84	1.62	0.56	0.39
3/8"	0.93	0.21	0.10	1.01	1.86	0.69	0.39
1/2"	1.12	0.25	0.10	1.20	2.24	0.85	0.39
3/4"	1.31	0.27	0.12	1.46	2.62	1.07	0.51
1"	1.50	0.30	0.13	1.77	3.00	1.33	0.51
1-1/4"	1.75	0.34	0.14	2.15	3.50	1.68	0.51
1-1/2"	1.93	0.37	0.15	2.43	3.86	1.92	0.51
2"	2.25	0.42	0.17	2.96	4.50	2.41	0.63
2-1/2"	2.68	0.48	0.21	3.31	5.36	2.91	0.63
3"	3.06	0.55	0.23	4.00	6.12	3.54	0.63
4"	3.81	0.66	0.26	5.06	7.62	4.55	0.75

UNIONS F/F

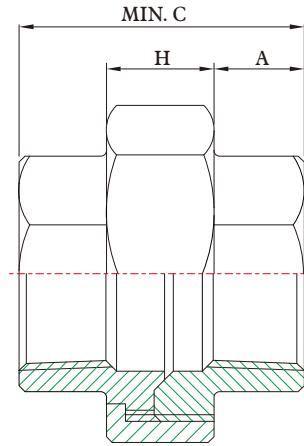

Thread End

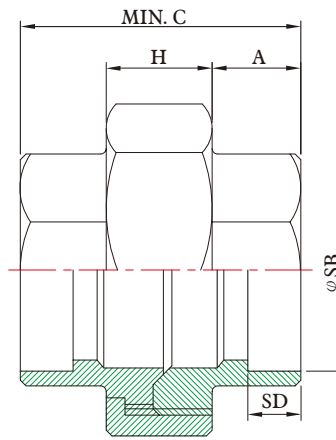
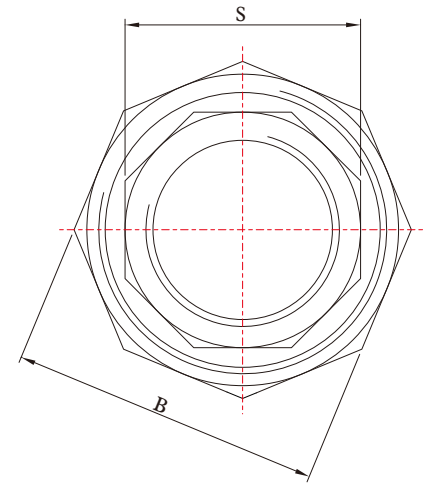

Socket-Weld End

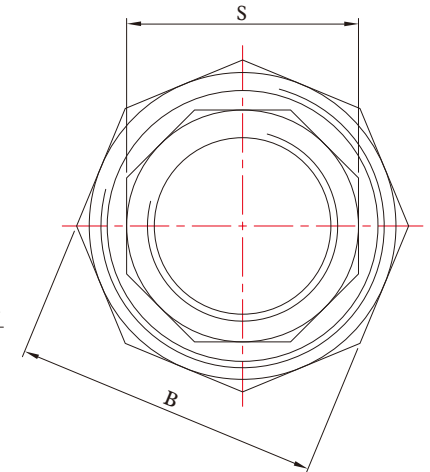

DESIGN FEATURES:

- THREAD: NPT
- CF8 (304) & CF8M (316)
- MEET MSS-SP114

DIMENSIONS

UNIT : inch

SIZE	A	B	C	H	S	SB	SD
1/8"	0.34	1.14	1.26	0.59	0.71	0.43	0.39
1/4"	0.43	1.14	1.44	0.59	0.71	0.56	0.39
3/8"	0.52	1.42	1.61	0.59	0.89	0.69	0.39
1/2"	0.57	1.61	1.72	0.59	1.06	0.85	0.39
3/4"	0.67	1.93	1.94	0.61	1.26	1.07	0.51
1"	0.68	2.28	2.06	0.71	1.59	1.33	0.51
1-1/4"	0.72	2.67	2.26	0.84	1.97	1.68	0.51
1-1/2"	0.78	3.02	2.41	0.87	2.20	1.92	0.51
2"	0.89	3.60	2.75	0.98	2.72	2.41	0.63
2-1/2"	1.11	4.29	3.22	0.98	3.36	2.91	0.63
3"	1.18	4.92	3.50	1.15	3.94	3.54	0.63
4"	1.26	6.14	3.85	1.35	5.00	4.55	0.75

ROUND CAPS

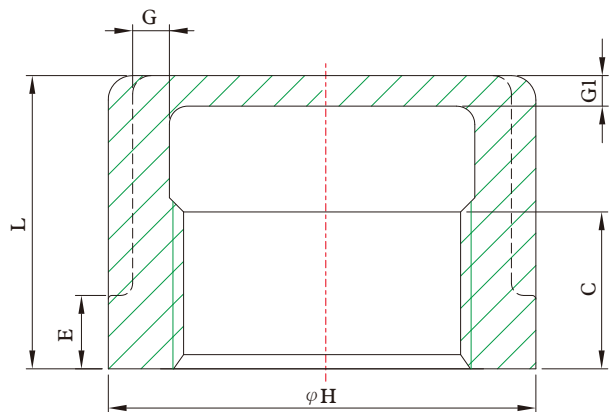

Thread End

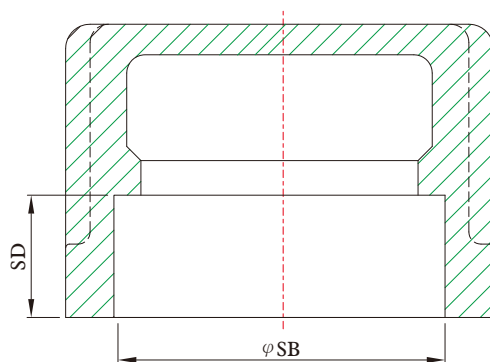

Socket-Weld End

DESIGN FEATURES:

- 🔴 THREAD: NPT
- 🔴 CF8 (304) & CF8M (316)
- 🔴 MEET MSS-SP114

DIMENSIONS

UNIT : inch

SIZE	C	E	G	G1	H	L	SB	SD
1/8"	0.25	0.20	0.09	0.09	0.75	0.68	0.43	0.39
1/4"	0.32	0.20	0.09	0.09	0.84	0.68	0.56	0.39
3/8"	0.36	0.21	0.10	0.10	1.01	0.81	0.69	0.39
1/2"	0.43	0.25	0.10	0.12	1.20	0.93	0.85	0.39
3/4"	0.50	0.27	0.12	0.13	1.46	1.06	1.07	0.51
1"	0.58	0.30	0.13	0.15	1.77	1.31	1.33	0.51
1-1/4"	0.67	0.34	0.14	0.17	2.15	1.62	1.68	0.51
1-1/2"	0.70	0.37	0.15	0.19	2.43	1.62	1.92	0.51
2"	0.75	0.42	0.17	0.22	2.96	1.75	2.41	0.63
2-1/2"	0.92	0.48	0.21	0.25	3.31	2.00	2.91	0.63
3"	0.98	0.55	0.23	0.29	4.00	2.25	3.54	0.63
4"	1.08	0.66	0.26	0.36	5.06	2.50	4.55	0.75

SQUARE HEAD PLUGS

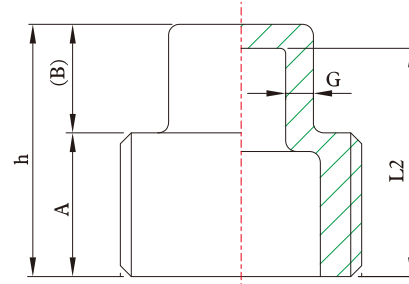
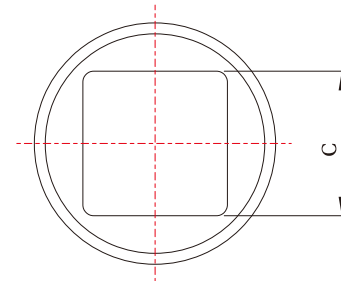

DESIGN FEATURES:

- 🔴 THREAD: NPT
- 🔴 CF8 (304) & CF8M (316)
- 🔴 MEET MSS-SP114

DIMENSIONS

UNIT : inch

SIZE	A	(B)	C	L2	h	G
1/8"	0.37	0.24	0.28	-----	0.61	-----
1/4"	0.44	0.28	0.37	-----	0.72	-----
3/8"	0.48	0.31	0.44	-----	0.79	-----
1/2"	0.56	0.38	0.56	0.78	0.94	0.16
3/4"	0.63	0.44	0.63	0.89	1.07	0.18
1"	0.75	0.50	0.81	1.05	1.25	0.20
1-1/4"	0.80	0.56	0.94	1.15	1.37	0.22
1-1/2"	0.83	0.62	1.13	1.21	1.45	0.24
2"	0.88	0.68	1.31	1.30	1.56	0.26
2-1/2"	1.07	0.74	1.50	1.52	1.81	0.29
3"	1.13	0.80	1.69	1.62	1.93	0.31
4"	1.22	1.00	2.25	1.84	2.22	0.38

HEX HEAD PLUGS

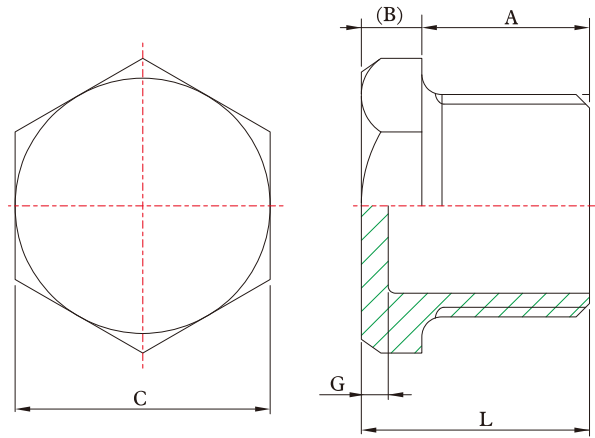

DESIGN FEATURES:

- THREAD: NPT
- CF8 (304) & CF8M (316)
- MEET MSS-SP114

DIMENSIONS

UNIT : inch

SIZE	A	B	C	G	L
1/8"	0.37	0.14	0.55	-----	0.51
1/4"	0.44	0.14	0.67	-----	0.58
3/8"	0.48	0.16	0.83	-----	0.64
1/2"	0.56	0.19	1.02	0.16	0.76
3/4"	0.63	0.22	1.20	0.18	0.85
1"	0.75	0.25	1.43	0.20	1.00
1-1/4"	0.80	0.28	1.76	0.22	1.09
1-1/2"	0.83	0.31	2.00	0.24	1.14
2"	0.88	0.34	2.48	0.26	1.22
2-1/2"	1.07	0.37	2.98	0.29	1.44
3"	1.13	0.40	3.86	0.31	1.53
4"	1.22	0.50	4.63	0.38	1.72

HEX NUTS

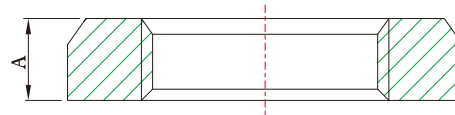
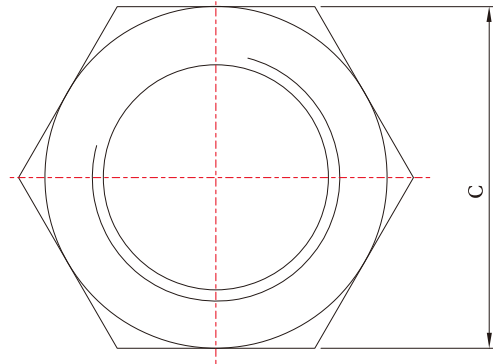
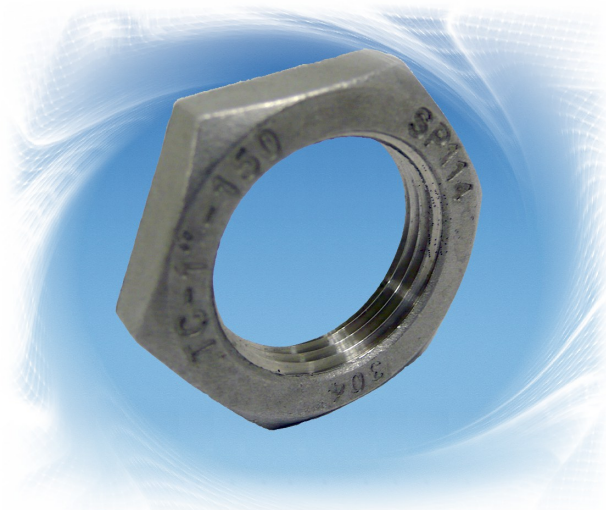

DESIGN FEATURES:

- 🔴 THREAD: NPT
- 🔴 CF8 (304) & CF8M (316)
- 🔴 MEET MSS-SP114

DIMENSIONS

UNIT : inch

SIZE	A	C
1/8"	0.19	0.69
1/4"	0.25	0.84
3/8"	0.28	1.00
1/2"	0.31	1.18
3/4"	0.34	1.43
1"	0.38	1.75
1-1/4"	0.42	2.10
1-1/2"	0.47	2.35
2"	0.53	2.88
2-1/2"	0.59	3.50
3"	0.67	4.02
4"	0.80	5.04

HEX BUSHINGS

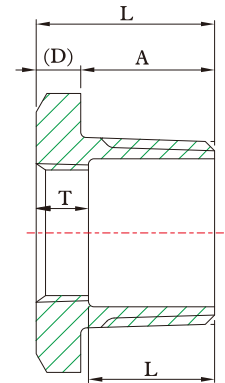
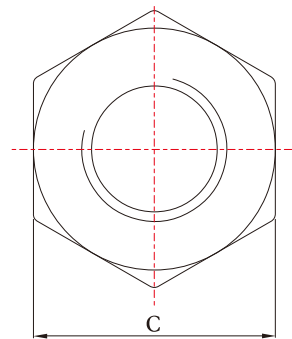

DESIGN FEATURES:

- THREAD: NPT
- CF8 (304) & CF8M (316)
- MEET MSS-SP114

DIMENSIONS

UNIT : inch

SIZE	A	C	D	L	T
1/4"×1/8"	0.44	0.63	0.12	0.56	0.30
3/8"×1/8"	0.50	0.87	0.16	0.66	0.30
3/8"×1/4"	0.50	0.87	0.16	0.66	-----
1/2"×1/8"	0.56	1.00	0.19	0.76	0.30
1/2"×1/4"	0.56	1.00	0.19	0.76	0.46
1/2"×3/8"	0.56	1.00	0.19	0.76	-----
3/4"×1/8"	0.62	1.24	0.22	0.84	0.30
3/4"×1/4"	0.62	1.24	0.22	0.84	0.46
3/4"×3/8"	0.62	1.24	0.22	0.84	0.46
3/4"×1/2"	0.62	1.24	0.22	0.84	-----
1"×1/8"	0.75	1.37	0.25	1.00	0.30
1"×1/4"	0.75	1.37	0.25	1.00	0.46
1"×3/8"	0.75	1.37	0.25	1.00	0.46
1"×1/2"	0.75	1.37	0.25	1.00	0.60
1"×3/4"	0.75	1.37	0.25	1.00	0.62
1 1/4"×1/4"	0.81	1.75	0.28	1.09	0.46
1 1/4"×3/8"	0.81	1.75	0.28	1.09	0.46
1 1/4"×1/2"	0.81	1.75	0.28	1.09	0.60
1 1/4"×3/4"	0.81	1.75	0.28	1.09	0.62
1 1/4"×1"	0.81	1.75	0.28	1.09	0.77
1 1/2"×1/4"	0.81	2.00	0.31	1.12	0.46
1 1/2"×3/8"	0.81	2.00	0.31	1.12	0.46
1 1/2"×1/2"	0.81	2.00	0.31	1.12	0.60
1 1/2"×3/4"	0.81	2.00	0.31	1.12	0.62
1 1/2"×1"	0.81	2.00	0.31	1.12	0.77
1 1/2"×1 1/4"	0.81	2.00	0.31	1.12	0.80



HEX BUSHINGS

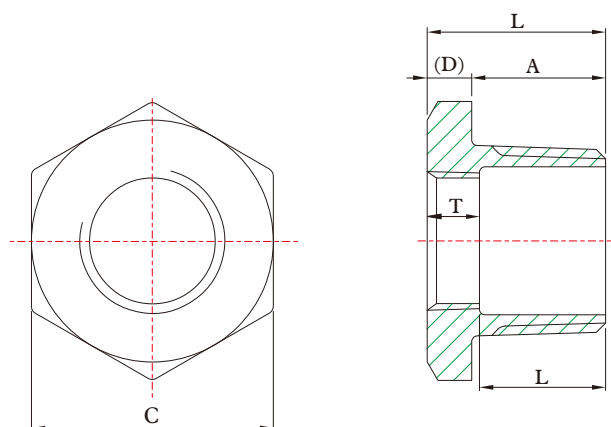

DESIGN FEATURES:

- THREAD: NPT
- CF8 (304) & CF8M (316)
- MEET MSS-SP114

DIMENSIONS

UNIT : inch

SIZE	A	C	D	L	T
2"*1/4"	0.88	2.50	0.34	1.22	0.46
2"*3/8"	0.88	2.50	0.34	1.22	0.46
2"*1/2"	0.88	2.50	0.34	1.22	0.60
2"*3/4"	0.88	2.50	0.34	1.22	0.62
2"*1"	0.88	2.50	0.34	1.22	0.77
2"*1 1/4"	0.88	2.50	0.34	1.22	0.80
2"*1 1/2"	0.88	2.50	0.34	1.22	0.81
2 1/2"*1/2"	1.06	3.00	0.38	1.44	0.65
2 1/2"*3/4"	1.06	3.00	0.38	1.44	0.62
2 1/2"*1"	1.06	3.00	0.38	1.44	0.75
2 1/2"*1 1/4"	1.06	3.00	0.38	1.44	0.80
2 1/2"*1 1/2"	1.06	3.00	0.38	1.44	0.81
2 1/2"*2"	1.06	3.00	0.38	1.44	0.85
3"*1/2"	1.12	3.74	0.41	1.54	0.65
3"*3/4"	1.12	3.74	0.41	1.54	0.62
3"*1"	1.12	3.74	0.41	1.54	0.75
3"*1 1/4"	1.12	3.74	0.41	1.54	0.79
3"*1 1/2"	1.12	3.74	0.41	1.54	0.81
3"*2"	1.12	3.74	0.41	1.54	0.85
3"*2 1/2"	1.12	3.74	0.41	1.54	1.23
4"*1"	1.25	4.63	0.60	1.85	0.77
4"*1 1/4"	1.25	4.63	0.60	1.85	0.79
4"*1 1/2"	1.25	4.63	0.60	1.85	0.81
4"*2"	1.25	4.63	0.60	1.85	0.85
4"*2 1/2"	1.25	4.63	0.60	1.85	1.23
4"*3"	1.25	4.63	0.60	1.85	1.33

COUPLINGS / SOCKETS

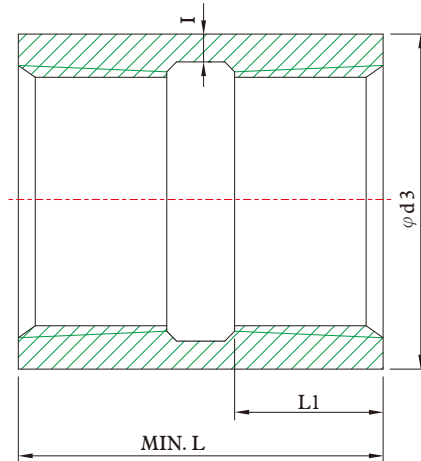

Thread End

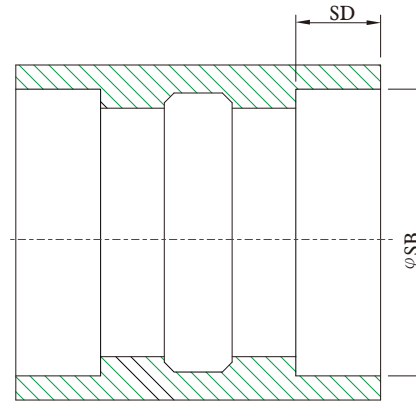

Socket-Weld End

DESIGN FEATURES:

- 🔴 THREAD: NPT
- 🔴 CF8 (304) & CF8M (316)
- 🔴 MEET MSS-SP114

DIMENSIONS

UNIT : inch

SIZE	d3	I	L	L1	SB	SD
1/8"	0.75	0.09	1.00	0.25	0.43	0.39
1/4"	0.84	0.09	1.00	0.32	0.56	0.39
3/8"	1.01	0.10	1.12	0.36	0.69	0.39
1/2"	1.20	0.10	1.38	0.43	0.85	0.39
3/4"	1.46	0.12	1.50	0.50	1.07	0.51
1"	1.77	0.13	1.62	0.58	1.33	0.51
1-1/4"	2.15	0.14	2.00	0.67	1.68	0.51
1-1/2"	2.43	0.15	2.12	0.70	1.92	0.51
2"	2.96	0.17	2.50	0.75	2.41	0.63
2-1/2"	3.31	0.21	2.87	0.92	2.91	0.63
3"	4.00	0.23	3.18	0.98	3.54	0.63
4"	5.06	0.26	3.68	1.08	4.55	0.75

HALF COUPLINGS

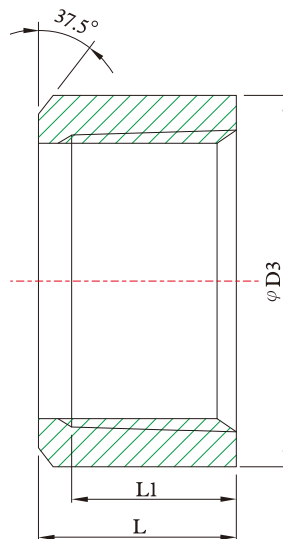
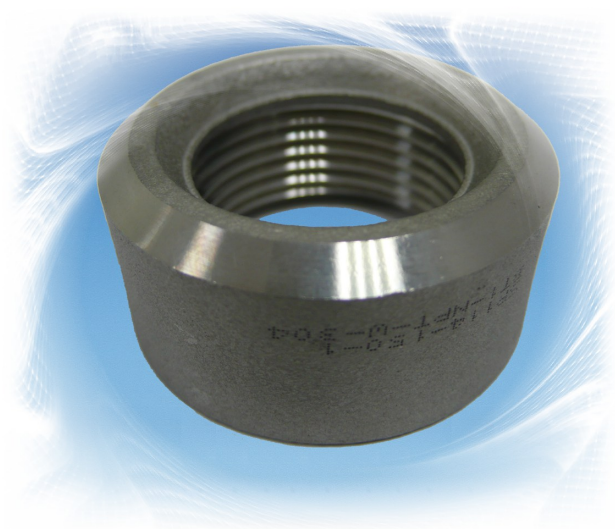

BSPT,NPT

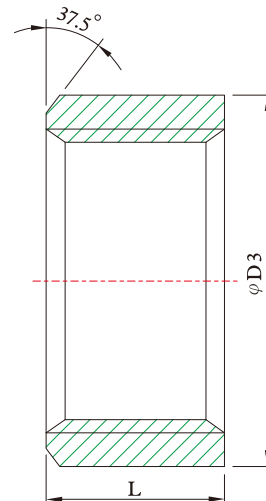

BSP,DIN2999

DESIGN FEATURES:

- ☛ THREAD: NPT
- ☛ CF8 (304) & CF8M (316)
- ☛ MEET MSS-SP114

DIMENSIONS

UNIT : inch

SIZE	D3	L	L1
1/8"	0.75	0.50	0.25
1/4"	0.84	0.50	0.32
3/8"	1.01	0.56	0.36
1/2"	1.20	0.69	0.43
3/4"	1.46	0.75	0.50
1"	1.77	0.81	0.58
1-1/4"	2.15	1.00	0.67
1-1/2"	2.43	1.06	0.70
2"	2.96	1.25	0.75
2-1/2"	3.31	1.44	0.92
3"	4.00	1.59	0.98
4"	5.06	1.84	1.08

REDUCING COUPLINGS

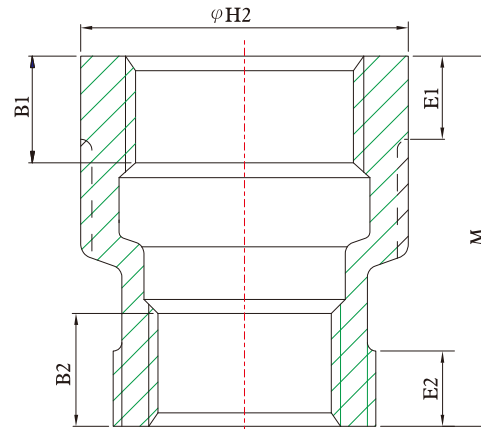

DESIGN FEATURES:

- THREAD: NPT
- CF8 (304) & CF8M (316)
- MEET MSS-SP114

DIMENSIONS

UNIT : inch

SIZE	h2	H2	B1	B2	E1	E2	M
1/4"×1/8"	0.75	0.84	0.32	0.25	0.20	0.20	1.00
3/8"×1/8"	0.75	1.01	0.36	0.25	0.21	0.20	1.12
3/8"×1/4"	0.84	1.01	0.36	0.32	0.21	0.20	1.12
1/2"×1/8"	0.75	1.20	0.43	0.25	0.25	0.20	1.38
1/2"×1/4"	0.84	1.20	0.43	0.32	0.25	0.20	1.38
1/2"×3/8"	1.01	1.20	0.43	0.36	0.25	0.21	1.38
3/4"×1/8"	0.75	1.46	0.50	0.25	0.27	0.20	1.50
3/4"×1/4"	0.84	1.46	0.50	0.32	0.27	0.20	1.50
3/4"×3/8"	1.01	1.46	0.50	0.36	0.27	0.21	1.50
3/4"×1/2"	1.20	1.46	0.50	0.43	0.27	0.25	1.50
1"×1/8"	0.75	1.77	0.58	0.25	0.30	0.20	1.62
1"×1/4"	0.84	1.77	0.58	0.32	0.30	0.20	1.62
1"×3/8"	1.01	1.77	0.58	0.36	0.30	0.21	1.62
1"×1/2"	1.20	1.77	0.58	0.43	0.30	0.25	1.62
1"×3/4"	1.46	1.77	0.58	0.50	0.30	0.27	1.62
1 1/4"×1/4"	1.77	2.96	0.75	0.58	0.42	0.30	2.50
1 1/4"×3/8"	2.15	2.96	0.75	0.67	0.42	0.34	2.50
1 1/4"×1/2"	2.43	2.96	0.75	0.70	0.42	0.37	2.50
1 1/4"×3/4"	1.46	3.31	0.92	0.50	0.48	0.27	3.25
1 1/4"×1"	1.77	3.31	0.92	0.58	0.48	0.30	3.25
1 1/2"×1/4"	2.15	3.31	0.92	0.67	0.48	0.34	3.25
1 1/2"×3/8"	2.43	3.31	0.92	0.70	0.48	0.37	3.25
1 1/2"×1/2"	2.96	3.31	0.92	0.75	0.48	0.42	3.25
1 1/2"×3/4"	1.46	4.00	0.98	0.50	0.55	0.27	3.68

REDUCING COUPLINGS

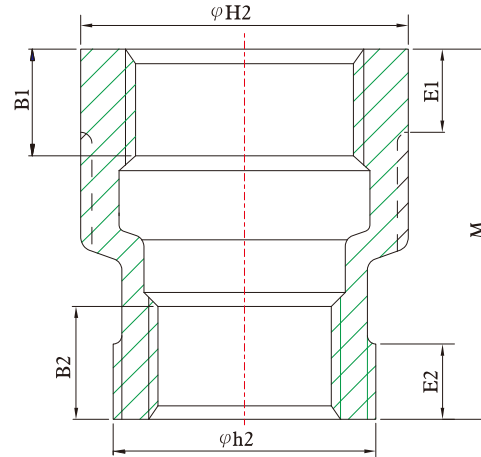

DESIGN FEATURES:

- THREAD: NPT
- CF8 (304) & CF8M (316)
- MEET MSS-SP114

DIMENSIONS

UNIT : inch

SIZE	h2	H2	B1	B2	E1	E2	M
1 1/2"×1"	2.15	2.43	0.70	0.67	0.37	0.34	2.12
2"×1/4"	0.84	2.96	0.75	0.32	0.42	0.20	2.50
2"×3/8"	1.01	2.96	0.75	0.36	0.42	0.21	2.50
2"×1/2"	1.20	2.96	0.75	0.43	0.42	0.25	2.50
2"×3/4"	1.46	2.96	0.75	0.50	0.42	0.27	2.50
2"×1"	1.77	2.96	0.75	0.58	0.42	0.30	2.50
2"×1 1/4"	2.15	2.96	0.75	0.67	0.42	0.34	2.50
2"×1 1/2"	2.43	2.96	0.75	0.70	0.42	0.37	2.50
2 1/2"×3/4"	1.46	3.31	0.92	0.50	0.48	0.27	3.25
2 1/2"×1"	1.77	3.31	0.92	0.58	0.48	0.30	3.25
2 1/2"×1 1/4"	2.15	3.31	0.92	0.67	0.48	0.34	3.25
2 1/2"×1 1/2"	2.43	3.31	0.92	0.70	0.48	0.37	3.25
2 1/2"×2"	2.96	3.31	0.92	0.75	0.48	0.42	3.25
3"×3/4"	1.46	4.00	0.98	0.50	0.55	0.27	3.68
3"×1"	1.77	4.00	0.98	0.58	0.55	0.30	3.68
3"×1 1/4"	2.15	4.00	0.98	0.67	0.55	0.34	3.68
3"×1 1/2"	2.43	4.00	0.98	0.70	0.55	0.37	3.68
3"×2"	2.96	4.00	0.98	0.75	0.55	0.42	3.68
3"×2 1/2"	3.31	4.00	0.98	0.92	0.55	0.48	3.68
4"×1"	1.77	5.06	1.08	0.58	0.66	0.30	4.38
4"×1 1/4"	2.15	5.06	1.08	0.67	0.66	0.34	4.38
4"×1 1/2"	2.43	5.06	1.08	0.70	0.66	0.37	4.38
4"×2"	2.96	5.06	1.08	0.75	0.66	0.42	4.38
4"×2 1/2"	3.31	5.06	1.08	0.92	0.66	0.48	4.38
4"×3"	4.00	5.06	1.08	0.98	0.66	0.55	4.38

150LB MSS-SP114 CAST FITTINGS

STANDARD PACKING QUALITY FOR EACH CARTON

unit:pcs

SIZE ITEM	1/8"	1/4"	3/8"	1/2"	3/4"	1"	1-1/4"	1-1/2"	2"	2-1/2"	3"	4"
90° ELBOWS BANDED EQUAL (P9B)	400	400	200	100	75	40	25	18	10	5	3	1
TEES BANDED EQUAL (PTB)	*200	250	125	75	50	30	16	14	8	4	2	1
45° ELBOWS BANDED EQUAL (P4B)	550	400	200	125	75	50	30	20	12	6	4	2
STREET ELBOWS 90° BANDED (PSL)	600	400	250	150	75	40	25	18	10	6	4	2
CROSSES BANDED EQUAL (P+B)	250	150	100	50	40	20	14	12	6	3	2	1
UNIONS F/F (PFF)	200	175	125	75	50	30	25	18	10	6	4	2
ROUND CAPS (PRC)	800	600	400	250	150	100	60	50	30	18	12	6
SQUARE HEAD PLUGS (PSP)	*900	*800	600	400	250	175	100	60	40	24	20	8
HEX HEAD PLUGS (PHP)	1,000	750	600	350	200	120	70	60	30	18	12	5
HEX NUTS (PHI)	1,000	1,000	600	500	300	200	150	120	50	40	25	15
HEX BUSHINGS (PHB)	-	900	600	350	225	125	90	64	40	24	12	6
COUPLINGS/SOCKETS (PFC)	450	400	250	150	100	70	40	30	24	12	8	4
HALF COUPLINGS (PHC)	1,200	600	400	300	200	125	120	90	48	24	16	8
REDUCING COUPLINGS (PRS)	-	500	250	150	100	50	36	30	18	10	8	3

SIZE OF CARTON: 1).1in x 0.65in x 0.89in
*2).1in x 0.65in x 0.45in



150LB MSS-SP114 CAST FITTINGS

WEIGHT LIST

unit:LB/PC

ITEM	1/8"	1/4"	3/8"	1/2"	3/4"	1"	1-1/4"	1-1/2"	2"	2-1/2"	3"	4"
90° ELBOWS BANDED EQUAL (P9B)	0.104	0.110	0.181	0.262	0.434	0.679	1.019	1.387	2.159	2.889	4.679	8.423
TEES BANDED EQUAL (PTB)	0.154	0.168	0.260	0.370	0.604	0.915	1.409	1.826	2.889	3.797	5.799	10.203
45° ELBOWS BANDED EQUAL (P4B)	0.101	0.112	0.174	0.247	0.395	0.595	0.926	1.171	1.859	2.304	3.757	6.284
STREET ELBOWS 90° BANDED (PSL)	0.073	0.099	0.163	0.238	0.386	0.613	0.990	1.369	2.176	3.614	5.570	10.198
CROSSES BANDED EQUAL (P+B)	0.165	0.201	0.300	0.432	0.692	1.072	1.592	2.093	3.301	5.129	6.860	12.302
UNIONS F/F (PFF)	0.212	0.194	0.306	0.392	0.564	0.875	1.305	1.658	2.529	4.359	5.521	8.884
ROUND CAPS (PRC)	0.046	0.060	0.088	0.137	0.223	0.384	0.617	0.794	1.208	1.722	2.690	4.666
SQUARE HEAD PLUGS (PSP)	0.034	0.073	0.126	0.199	0.306	0.564	0.895	1.220	1.896	3.083	4.493	8.509
HEX HEAD PLUGS (PHP)	0.044	0.083	0.151	0.229	0.370	0.588	0.977	1.303	2.052	3.447	5.465	9.384
HEX NUTS (PHI)	0.013	0.026	0.042	0.057	0.090	0.132	0.203	0.271	0.437	0.725	0.882	1.469
HEX BUSHINGS (PHB)	-	0.020	0.035	0.073	0.128	0.216	0.373	0.525	0.904	1.413	2.159	4.161
COUPLINGS/SOCKETS (PFC)	0.209	0.233	0.360	0.559	0.856	1.293	2.061	2.664	4.128	4.672	6.904	11.304
HALF COUPLINGS (PHC)	0.117	0.136	0.199	0.316	0.462	0.705	1.138	1.512	2.261	2.757	4.079	6.379
REDUCING COUPLINGS (PRS)	-	0.077	0.112	0.176	0.265	0.421	0.626	0.847	1.330	2.044	2.994	5.074

